

Article 258A - Technical Regulations for Sports Racing Cars

SUMMARY

ARTICLE 1 : DEFINITIONS

- 1.1 Sports Racing Car
- 1.2 Automobile
- 1.3 Land Vehicle
- 1.4 Automobile make
- 1.5 Main structure
- 1.6 Bodywork
- 1.7 Event
- 1.8 Weight
- 1.9 Racing weight
- 1.10 Wheel
- 1.11 Cockpit
- 1.12 Supercharging
- 1.13 Suspension
- 1.14 Active suspension
- 1.15 Mechanical components
- 1.16 Telemetry
- 1.17 Semi-automatic gearbox
- 1.18 Brake callipers
- 1.19 Location
- 1.20 Position
- 1.21 Orientation

ARTICLE 2 : REGULATIONS

- 2.1 Role of the FIA
- 2.2 Permitted modifications
- 2.3 Vehicle type eligibility
- 2.4 Regulation and eligibility amendments
- 2.5 Compliance with the regulations
- 2.6 Measurements
- 2.7 Electronic system
- 2.8 Material

ARTICLE 3 : BODYWORK AND EXTERIOR DIMENSIONS

- 3.1 Dimensions
- 3.2 Overhangs and wheelbase
- 3.3 Windscreen
- 3.4 Bodywork
- 3.5 Flat bottom (Reference Surface)
- 3.6 Aerodynamic devices

ARTICLE 4 : WEIGHT

- 4.1 Minimum weight
- 4.2 Ballast
- 4.3 Adding during the race
- 4.4 Liquids

ARTICLE 5 : ENGINE

- 5.1 General
- 5.2 Elements banned
- 5.3 Normally aspirated engines
- 5.4 Supercharged engines
- 5.5 Temperature of the charge
- 5.6 Cooling
- 5.7 Exhaust
- 5.8 Telemetry

ARTICLE 6 : FUEL PIPING, PUMPS AND TANKS

- 6.1 Fuel tank
- 6.2 Fittings and piping
- 6.3 Fuel tank fillers
- 6.4 Refuelling during the race
- 6.5 Fuel capacity

ARTICLE 7 : LUBRICATION SYSTEM

- 7.1 Oil tanks

- 7.2 Catch tank

ARTICLE 8 : ELECTRICAL EQUIPMENT

- 8.1 Battery
- 8.2 Starting
- 8.3 Lighting equipment

ARTICLE 9 : TRANSMISSION

- 9.1 Transmission to the wheels
- 9.2 Reverse gear
- 9.3 Clutch

ARTICLE 10 : SUSPENSION AND STEERING

- 10.1 Sprung suspension
- 10.2 Suspension type and mounting
- 10.3 Chromium plating
- 10.4 Suspension members
- 10.5 Steering
- 10.6 Power steering
- 10.7 Four-wheel steering

ARTICLE 11 : BRAKES

- 11.1 Separate circuits
- 11.2 Brake discs
- 11.3 Anti-lock and power braking
- 11.4 Brake callipers

ARTICLE 12 : WHEELS AND TYRES

- 12.1 Dimensions
- 12.2 Wheel visibility
- 12.3 Wheel material
- 12.4 Number of wheels
- 12.5 Wheel attachment
- 12.6 Pneumatic jacks
- 12.7 Pressure control valves

ARTICLE 13 : COCKPIT

- 13.1 Cockpit
- 13.2 Equipment permitted in the cockpit
- 13.3 Cockpit exit time
- 13.4 Volumes for occupants' legs
- 13.5 Protection of the driver
- 13.6 Lateral protections
- 13.7 Cockpit opening
- 13.8 Cockpit isolation

ARTICLE 14 : SAFETY EQUIPMENT

- 14.1 Fire extinguishers
- 14.2 Safety belts
- 14.3 Rear view mirrors
- 14.4 Seat and headrest
- 14.5 Master switch
- 14.6 Towing eye

ARTICLE 15 : SAFETY STRUCTURES

- 15.1 Magnesium sheet
- 15.2 Rollover structures
- 15.3 Safety structures
- 15.4 Firewall
- 15.5 Composite chassis

ARTICLE 16 : FUEL

- 16.1 Fuel specification
- 16.2 Air

ARTICLE 17 : FINAL TEXT

ARTICLE 1 : DEFINITIONS**1.1 Sports Racing Car**

Two-seater open racing car, built for the sole purpose of taking part in races on closed circuits.

The two seats must be situated one on each side of the longitudinal centre line of the car, and must be crossed by the same transversal plane.

1.2 Automobile

A land vehicle running on at least four non-aligned complete wheels, of which at least two are used for steering and at least two for propulsion.

1.3 Land vehicle

A locomotive device, propelled by its own means, moving by constantly taking real support on the earth's surface, and of which the propulsion and steering are under the control of a driver aboard the vehicle.

1.4 Automobile make

An automobile make is a complete car.

When the manufacturer of the car fits an engine not manufactured by himself, the car shall be considered as a hybrid and the name of the engine manufacturer shall be associated with the name of the car manufacturer.

The name of the car manufacturer shall always precede that of the engine manufacturer.

Any Trophy, Cup or Champion Title won by a hybrid car shall be awarded to the manufacturer of the car.

1.5 Main structure

Entirely sprung part of the structure of the vehicle, to which all the suspension and/or spring loads are transmitted, extending longitudinally from the foremost suspension mounting point on the chassis to the rearmost suspension mounting point on the chassis.

1.6 Bodywork

All entirely sprung parts of the car in contact with the external air stream, except the parts definitely associated with the mechanical functioning of the engine, transmission and running gear.

Any air intake shall be considered to be part of the bodywork.

Viewed from above, from the side and from the rear, the bodywork must conceal all mechanical components.

The bodywork parts must not be mobile.

1.7 Event

An event shall consist of official practice and the race.

1.8 Weight

Is the weight of the car without the driver at any moment during the event and without fuel.

1.9 Racing weight

Is the weight of the car in running order with the driver aboard and the fuel tank full.

1.10 Wheel

Wheel : Flange and rim.

Complete wheel : Flange, rim and tyre.

1.11 Cockpit

The volume of the main structure which is reserved for the occupants.

Nothing is permitted to cover the cockpit opening as seen from above except rollbar reinforcements.

1.12 Supercharging

Increasing the weight of the charge of the fuel-air mixture in the combustion chamber (over the weight induced by normal atmospheric pressure, ram effect and dynamic effects in the intake and/or exhaust system) by any means whatsoever.

The injection of fuel under pressure is not considered to be supercharging.

1.13 Suspension

The means whereby all complete wheels are suspended from the body/chassis unit by a spring medium.

1.14 Active suspension

Any system which allows control of the flexibility and/or the damping of any part of the suspension or of the trim height when the car is moving.

1.15 Mechanical components

All those necessary for the propulsion, suspension, steering and braking, as well as all accessories, whether moving or not, which are necessary for their normal working.

1.16 Telemetry

The transmission of data between a moving car and anyone connected with the entry of that car in the event.

1.17 Semi-automatic gearbox

One which, when the driver calls for a gear change, takes over the control of one or more of the engine, clutch and gear selectors momentarily to enable the gear to be engaged.

1.18 Brake callipers

All parts of the braking system outside the survival cell, other than brake discs, brake pads, calliper pistons, brake hoses, master cylinder and fittings, which are stressed when subjected to the braking pressure.

1.19 Location

A site defined relative to the centre line of the car, axles centre (middle of the wheelbase on the centre line), cockpit, engine compartment.

Location within the engine compartment is a site defined relative to the crank case and cylinder head(s).

1.20 Position

The site defined by dimensions from the original vehicle data, e.g. axle centres and centre line of the car.

1.21 Orientation

Is the relationship of the component to the longitudinal and transversal axes of the vehicle.

If the component is turned 180°, this will be regarded as a change in orientation.

ARTICLE 2 : REGULATIONS**2.1 Role of the FIA**

The following technical regulations for Sports Racing Cars **and Sports Racing Cars Light** are issued by the FIA.

2.2 Permitted modifications

All modifications not allowed by these regulations are expressly forbidden.

2.3 Vehicle type eligibility

Vehicles will be eligible in the Sports Racing Cars class **or in the Sports Racing Cars Light class (see Article 17)**.

To be eligible in the Sports Racing Cars class **or in the Sports Racing Cars Light class**, a vehicle must have a technical form for Sports Racing Cars, delivered by the FIA.

2.4 Regulation and eligibility amendments

Each year in October at the latest the FIA will publish changes made to these regulations.

All such changes will take effect on the second 1st of January following their publication.

Changes for safety reasons may be made without notice.

Changes covered by Articles 4.1.2, 5.3.4, 5.4.5 and 6.5.2 will be made in accordance with the period of notice specified in the relevant Sporting Regulations, save in circumstances deemed to be exceptional by the governing body of the relevant Championship.

2.5 Compliance with the regulations

It is the duty of each competitor to satisfy the Scrutineers and the Stewards of the Meeting that his car complies with these regulations in their entirety at all times during an event.

A car, the construction of which is deemed to be dangerous, may be excluded by the Stewards of the meeting.

2.6 Measurements

All measurements must be made while the car is stationary on a flat horizontal surface or as provided in the Sporting Regulations of the relevant Championship.

2.7 Electronic system

Any automatic or electronic chassis control system or function is forbidden.

This includes anti-lock braking, traction control, automatic or semi-automatic transmissions, power-driven clutches, electronically or automatically adjusted final drive differential systems, damper, suspension or ride height adjustment, power braking, four-wheel steering, movable ballast.

Semi-automatic or automatic gearboxes and differentials with electronic, pneumatic or hydraulic slip control are forbidden.

Closed-loop electronically controlled systems are prohibited.

A simple open-loop electrical switch activated by the driver acting on a system is not considered to be an electronic control. Power steering may be employed as long as it is a simple system, without programmable control.

2.8 Material

Titanium is not permitted unless explicitly authorised by the current regulations.

The use of a material which has a specific yield modulus greater than 40 GPa/g/cm³ is forbidden.

The use of magnesium sheet less than 3 mm thick is forbidden.

ARTICLE 3 : BODYWORK AND EXTERIOR DIMENSIONS

3.1 Dimensions

All bodywork dimensions and shape must comply with those specified on the technical form.

- Maximum overall length : 4650 mm
- Maximum overall width : 2000 mm
- Maximum height of the bodywork : 965 mm
(including the rear wing)
- Minimum height of the rear rollover structure: 1020 mm

Each height is measured from the Flat bottom (Reference Surface) defined in the Article 3.5.

3.2 Overhangs and wheelbase

The front and rear overhangs must comply with those specified on the technical form.

- Maximum front overhang : 1000 mm
- Maximum rear overhang : 1000 mm
- Minimum wheelbase : 2700 mm

Front plus rear overhangs must not exceed 80 **70** % of the wheelbase.

The difference between the front and rear overhangs must not exceed 15 **10** % of the wheelbase.

3.3 Windscreen

Optional.

3.4 Bodywork

The material used for the bodywork parts is free.

3.4.1)

Viewed from above and from the rear:

The bodywork must fully cover the wheels and tyres and all mechanical components, including the gearbox, above the wheel centre line level, with no empty space or cut-out in the bodywork (with the wheels aligned and the car positioned to go straight ahead).

Viewed from the side :

The wheel arches shall remain open.

3.4.2) Air inlets :

The only functions permitted for the air inlets are the cooling of the radiators and brakes, the air intake of the engine, and the ventilation of the engine compartment and cockpit.

They must channel all the airflow onto the elements to be cooled and have no aerodynamic influence to improve the handling of the car.

They must also respect the maximum body height as defined in article 3.1.

They must neither protrude beyond the perimeter of the bodywork as viewed from above, nor protrude above the surface of the bodywork by more than 150 mm (this does not apply to the engine air inlet).

3.4.3) Air outlets ; Louvres :

* Air outlets are permitted :

- on the front bonnet
- on the rear panel of the car up to the rear axle, provided that they do not allow the mechanical parts and the wheels to be seen from the rear and that they do not extend more than 20 mm beyond the surface of the bodywork.
- on the bodywork sides, provided they do not protrude beyond the perimeter of the bodywork.

Aft of the front and rear wheels, the openings made in the bodywork in order to extract air must not protrude beyond the perimeter of the car and must be situated below the plane passing through the front and rear axles' centrelines, whatever the static ride height of the car, as viewed from the side.

* Air extraction louvres are authorised on the rear vertical panel of the car provided that they do not allow the mechanical parts and the wheels to be seen from the rear.

These louvres must not extend more than 20 mm beyond the surface of the bodywork.

Louvres for air extraction are mandatory over the front wheels, with a minimum area of 160 cm² per wheel.

3.4.4) All parts of the bodywork, including any part having an aerodynamic influence, must be rigidly secured to the entirely sprung part of the car (chassis/body unit), must not have any

degree of freedom, must be securely fixed and remain immobile in relation to this part while the car is in motion.

3.4.5) There must be at least two safety fasteners securing bonnet/boot/engine covers, both of which are clearly indicated by red (or contrasting colour) arrows.

It must be possible to remove or open the bonnet and boot without the use of tools.

3.4.6) All bodywork joints in the vicinity of the refuelling connections must be designed in such a way as to prevent any leakage of fuel into the engine compartment and/or cockpit during refuelling.

3.4.7) Any device or construction that is designed to bridge the gap between the sprung part of the car and the ground is prohibited under all circumstances.

3.5 Flat bottom (Reference Surface)

Between the front and at least the rear axle centre lines, all bodywork visible from directly beneath the car must lie on one plane.

This plane, called Flat Bottom or Reference Surface, must be a uniform, solid, hard, rigid (no degree of freedom in relation to the body/chassis unit), impervious surface, under all circumstances. It is used as a reference for all the vertical measurements.

To help overcome any possible manufacturing problems, a tolerance of +/- 5 mm is permissible across this surface.

With the exception of the rear part of this surface, the periphery of the surface formed by these parts may be curved upwards with a maximum radius of 50 mm.

A block, the minimum dimensions of which are 20x100 mm, must be mounted on the Flat bottom, on the centre line of the car and on the rear axle centre line.

The lower surface of this block must never be less than 20 mm below the Flat bottom.

No sprung part of the car is permitted below the flat bottom and air may pass between the bodywork and the Flat Bottom, for cooling and ventilation purposes only.

No opening will be permitted in the Flat Bottom except for hatches necessary for maintenance, openings for air jacks (95 mm maximum diameter) and cutouts necessary for suspension parts travel.

3.6 Aerodynamic devices

3.6.1) Elements banned :

Tunnels, ducts, skirts, diffusers, extractors or other devices for the purpose of inducing downforce with or without the exterior shape of the body are prohibited behind the front axle centre line.

~~Any rear diffuser is forbidden.~~

3.6.2) Front aerodynamic devices :

Forward of the front axle centre line, no bodywork element having a wing profile is permitted.

Additional aerodynamic devices may be added to the front bodywork of the car :

- Below and forward of the front axle centre line
- Outboard of two longitudinal and vertical planes, symmetrical around the longitudinal centre line of the car and separated by the width of the front track

provided that :

- They do not obstruct the driver's view
- They are strongly secured
- They remain within the maximum dimensions specified in Article 3.1 and 3.2.

3.6.3) Rear wing :

The primary device permitted for exerting downforce (negative lift) shall be a non-movable, adjustable wing carried at the rear of the car.

This wing must not be adjustable from the cockpit, and must be rigid so that its angle or shape is not influenced by air pressure when the car is in motion.

The rear wing is made of the following parts :

Main wing ; Guard plates; Vertical supports.

- It must be no wider than the overall width of the car.
- It must be mounted such that no part is higher than 965 mm above the Reference Surface (Flat bottom).
- The main wing must be contained within a parallelogram of 150 x 400 mm horizontally and must have a maximum of 2 elements.
- Vertical supports and guard plates must have a maximum length of 520 mm horizontally.
- The gap between the guard plates and the bodywork must never be less than 100 mm.

- The surfaces of the guard plates must not be curved and must be parallel to the longitudinal axis of the car.

Only for cars designed as from 1 January 2000 :

~~It must be possible to remove the rear bodywork without disturbing the rear wing or its mounting in any way.~~

The rear wing must be rigidly attached to the main structure of the car, and not just to the bodywork.

3.6.4) Rear diffuser :

An inclined, perfectly flat panel (diffuser), limited by right angles and with only one opening for a pneumatic jack, is authorised.

It must be situated:

- **Between the rear edge of the flat bottom and the vertical plane formed by the rearmost element of the bodywork, with the car backed against a wall and the rear wing dismounted.**

- **Between the vertical planes formed by the inside faces of the rear wheels.**

Viewed from above and with the rear wing dismounted, the rear diffuser must remain inside the perimeter of the bodywork, and no part or panel of the bodywork, attached to the rear diffuser or not, may extend the inclined panel of the diffuser to the rear limit of the perimeter of the car.

Viewed from above, the trailing edge of the diffuser must not protrude beyond the perimeter of the bodywork.

Vertical fins may be added to the diffuser provided that they are parallel to the longitudinal axis of the car, that their surfaces are flat and parallel to one another and that they form right angles with the inclined panel of the diffuser.

The maximum width of the diffuser must be 1000 mm, measured inside the external vertical fins, and no part of the diffuser may be situated more than 150 mm above the flat bottom.

ARTICLE 4 : WEIGHT

4.1 Minimum weight

4.1.1) The weight of the car must not be less than 900 kg.

4.1.2) The right is reserved, by the Sporting Authority of the relevant Championship, to adjust the weight of any car to maximise equality of performance.

4.2 Ballast

Ballast must be secured such that tools are required for its removal and so as to allow the fixing of seals by the scrutineers.

4.3 Adding during the race

The adding to the car during the race of any solid material whatsoever or the replacement during the race of any part of the car with another which is materially heavier is forbidden.

4.4 Liquids

The weight may be checked at any time during the event with the quantity of liquids remaining in the tanks except after the race where the car will be emptied of all the fuel before weighing.

ARTICLE 5 : ENGINE

5.1 General

Provided the regulations in Articles 5.1 to 5.8 are complied with, the engine and ancillaries are free.

The make and type of engine used must remain identical to those specified on the technical form of the car.

5.2 Elements banned

5.2.1) Variable valve timing is not permitted.

5.2.2) Variable length inlet systems are not permitted.

5.2.3) Titanium is only permitted for connecting rods, valves and valve retainers.

5.2.4) The use of magnesium is not permitted.

5.2.5) The use of any ceramic component is forbidden.

5.2.6) The use of carbon or composite materials is restricted to clutches and non-stressed covers or ducts.

5.2.7) Only a direct mechanical linkage between the throttle pedal and the engine is permitted.

5.3 Normally aspirated engines

Engine types are limited to normally aspirated four-stroke, and rotary petrol engines.

5.3.1) Cylinder capacity :

The cylinder capacity is limited to 6000 cm³.

5.3.2) The engine air intake system must be fitted with one or two air restrictors 3 mm long with maximum diameters set out in Appendix 1.

5.3.3) All the air feeding the engine must pass through these restrictors, which must be made of metal or metal alloy.

5.3.4) The right is reserved, by the Sporting Authority of the relevant Championship, to adjust the size of these air restrictors to maximise equality of performance.

5.4 Supercharged engines

5.4.1) Cylinder capacity :

The maximum capacity of supercharged engines is 4000 cm³.

5.4.2) The engine air intake system must be fitted with one or two air restrictors 3 mm long with maximum diameters set out in Appendix 1.

5.4.3) All restrictors must comply with drawing 254-4, or may incorporate between the restrictor and the inlet diameter of the supercharging device a single-piece, airtight cone.

Each cone must have a minimum 7 degrees opening angle.

On each end and over a maximum length of 10 mm, a curved shape is permitted.

At the base of each cone, a radius is permitted within the diameter of the restrictor and the diameter of the supercharging device.

5.4.4) All the air feeding the engine must pass through these restrictors, which must be made of metal or metal alloy.

5.4.5) The right is reserved, by the Sporting Authority of the relevant Championship, to adjust the size of these air restrictors to maximise equality of performance.

5.4.6) Supercharged cars must not be equipped with any device which allows the boost pressure, or the electronic management system controlling the boost pressure, to be adjusted while the car is in motion.

5.4.7) Variable diameter inlets and adjustable internal vanes on turbochargers are forbidden.

5.4.8) Maximum (absolute) supercharging pressure :

See table, Appendix 1.

5.5 Temperature of the charge

5.5.1) Intercoolers are free and may be used for cooling intake air.

Apart from intercoolers, any device, system, procedure, construction or design the purpose and/or effect of which is any decrease whatsoever of the temperature of the intake air and/or of the charge (air and/or fuel) of the engine is forbidden.

The pipes between the supercharging device, the intercooler and the manifold are free, but their only function must be to channel the intake air.

5.5.2) Internal and/or external spraying or injection of water or any substance whatsoever is forbidden (other than fuel for the normal purpose of combustion in the engine).

5.6 Cooling

The cooling system is free.

5.7 Exhaust

Provided the regulations in Articles 5.7.1, 5.7.2, and 5.7.3 are complied with, the exhaust system is free.

5.7.1) The noise generated by the car is not to exceed 110 dB (A) at 3800 rpm, or at three quarter maximum revs if less.

This will be measured at a distance of 0.5 m and at a 45 degree angle to the point of exit of the exhaust.

For front-engined cars having the exhaust exit on the side of the car, the noise will be measured at 90° from the side of the car.

All measures which are taken to ensure that the maximum noise limits are not exceeded must be permanent in nature, and must not be removed by the exhaust gas pressure.

5.7.2) The orifices of the exhaust pipes must be placed at a maximum of 450 mm and a minimum of 100 mm from the ground.

The exit of the exhaust pipe must be situated within the perimeter of the car and less than 100 mm from this perimeter, and aft of the vertical and transversal plane passing through the centre of the wheelbase.

Moreover, adequate protection must be provided in order to prevent heated pipes from causing burns.

The exhaust system must not be provisional.

Exhaust gas may only exit at the end of the system.

Parts of the chassis must not be used to evacuate exhaust gases.

5.7.3) The exhaust system must be adequately isolated from the driver compartment.

5.8 Telemetry

The use of telemetry is forbidden.

ARTICLE 6 : FUEL PIPING, PUMPS AND TANKS

Provided the regulations in this Article are complied with, the fuel system is free.

6.1 Fuel tank

6.1.1) The fuel tank must be separated from the driver and the engine compartment by a firewall.

For safety reasons, the fuel tank must be installed between the two vertical and transversal planes touching the front of the front wheels and the rear of the rear wheels and two vertical planes parallel to and at a maximum distance of 675 mm from the central axis of the car.

The tank must be surrounded by a crushable structure at least 10 mm thick.

6.1.2) All fuel tanks must be rubber bladders conforming to or exceeding the specifications of FIA/FT3 or FIA/FT3 1999.

6.1.3) All rubber bladders must be made by manufacturers homologated by the FIA.

6.1.4) All rubber bladders shall have a printed code indicating the name of the manufacturer, the specifications to which the tank has been manufactured and the date of manufacture.

6.1.5) No rubber bladders shall be used more than 5 years after the date of manufacture, unless inspected and recertified by the manufacturer for a period of up to another 2 years.

6.2 Fittings and piping

A radiator is permitted in the fuel circuit.

6.2.1) All fittings which constitute the walls of the tank (including air vents, inlets, outlets, tank fillers, inter-tank connectors and access openings) must be metal or composite fittings bonded into the fuel tank.

6.2.2) All fuel lines between the fuel tank and the engine must have a self-sealing breakaway valve.

This valve must separate at less than 50 % of the load required to break the fuel line fitting or to pull it out of the fuel tank.

6.2.3) No lines containing fuel, cooling water or lubricating oil may pass through the cockpit.

The air vent(s) and their valves may pass through the cockpit provided that they are made from aviation type material and do not have any connections, other than to the (tank/roof) bulkheads.

The vent and filler spouts may pass through the cockpit as close to the walls as possible.

Their pipes must be made from metal and their connectors from material identical to that used for the walls of the tank.

They must be isolated from the cockpit by means of a leakproof protection.

6.2.4) All lines must be fitted in such a way that any leakage cannot result in accumulation of fluid in the cockpit.

6.2.5) When flexible, all lines must have threaded connectors and an outer braid which is resistant to abrasion and flame.

6.2.6) All fuel and lubricating oil lines must have a minimum burst pressure of 41 bar at the maximum operating temperature of 135°C.

6.2.7) All hydraulic fluid lines which are not subjected to abrupt changes in pressure, with the exception of lines under gravity head, must have a minimum burst pressure of 41 bar at the maximum operating temperature of 204°C when used with steel connectors and 135°C when used with aluminium connectors.

6.2.8) All hydraulic fluid lines subjected to abrupt changes in pressure must have a minimum burst pressure of 70 bar at the maximum operating temperature of 204°C.

6.2.9) No hydraulic fluid lines may have removable connectors inside the cockpit.

6.2.10) The vent lines must be fitted with a gravity-activated roll-over valve.

All the fuel pumps must operate only when the engine is running, except during the starting process.

6.2.11) The air ducts must be made from a non-flammable material.

6.3 Fuel tank fillers

6.3.1) All cars must be fitted with fuel tank fillers and vents which must be combined or single units, installed or not on both

sides of the car (in accordance with drawing 252-5; the interior diameter D must not exceed 50 mm).

Both fillers and air vents must be equipped with leakproof dry break couplings complying with the dead man principle and therefore not incorporating any retaining device when in an open position.

6.3.2) The tank fillers and vent holes must not protrude beyond the bodywork.

6.3.3) The tank fillers, vent holes, vents and breathers must be placed where they would not be vulnerable in the event of an accident.

6.3.4) Any vent or breather connecting the tank to atmosphere must exit on the outside of the bodywork, must be fitted with a non-return valve and must be designed in such a way as to avoid any liquid leakage when the car is running, upside down, or refuelling.

6.3.5) All cars must be fitted with a self-sealing connector which can be used by the scrutineers to obtain samples of the fuel feeding the engine.

This connector must be of the type approved by the FIA and must be fitted immediately before the injectors.

6.4 Refuelling during the race

6.4.1) Refuelling the car by any other means than gravity, with a maximum height of 2 metres above the track where the refuelling takes place, is forbidden throughout the event.

6.4.2) During the race, only one autonomous supply tank complying with drawing 252-7 must be used per car.

This tank must have a simple cylindrical internal shape and must not have any additional internal parts.

For safety reasons, this tank must be fixed, through a tower, onto a trolley with the following characteristics :

- all the tower components must be mechanically assembled without any degree of freedom in relation to the trolley
- the base of the trolley must have a surface area of at least 2 m² and must be made with a case fitted on 4 self-braking castors, ballasted with a weight greater than that of the tank filled with fuel.

A system for weighing the fuel may be applied through placing a weighing plate underneath the tank, provided that the characteristics set out above are respected.

A member for supporting the refuelling lines and air hoses may be attached to the trolley :

- it must be independent of the tank and of the tower.
- it is recommended that this member be allowed a degree of freedom in relation to the trolley (rotation following a vertical axis).
- it must not exceed 4 m in length and must allow a free passage of a height of 2 m over its entire length, including the accessories.
- an identification plate bearing the race number of the competing car must be fixed to its end.

A flow restrictor with the following dimensions:

- thickness: 2 mm
 - maximum internal diameter: 33 mm
- must be placed at the exit of the refuelling tank (see drawing 258-4).

6.4.3) Above the tank there must be an air vent system approved by the FIA.

6.4.4) The refuelling pipe, minimum length 250 cm, must be provided with a leakproof coupling to fit the filler mounted on the car, and during refuelling the outlet of the air vent must be connected with an appropriate coupling of the same diameter to the supply tank.

6.4.5) Before refuelling commences, the car and all metal parts of the refuelling system, from the coupling to the supply tank and its rack, must be connected electrically to earth by a manual contactor having no other function.

6.4.6) A 90° cut-off valve, situated on the outlet of the supply tank and controlling the fuel flow, must be manned at all times during refuelling.

A self-closing valve with an internal diameter of 38 mm must be fixed under the supply tank according to drawing 252-7.

6.4.7) All hoses and fittings used must have a maximum inside diameter of 1.5".

6.4.8) During practice, the standard supply tank or an unpressurised container not exceeding 25 litres capacity which is vented to air and has a leakproof coupling connecting it to the tank filler on the car can be used.

6.4.9) If a visible level is fitted to the tank, it must be fitted with isolating valves as close as possible to the tank.

6.4.10) The storing of fuel on board the car at a temperature less than 10°C below the ambient temperature is forbidden. The use of a specific device, whether on board the car or not, to reduce the temperature of the fuel below the ambient temperature is forbidden.

6.5 Fuel capacity

6.5.1) The maximum amount of fuel which may be carried on board is 90 litres.

Any device, system, procedure, construction or design, the purpose and/or effect of which is to increase in any way whatsoever, even temporarily, the total fuel storage capacity beyond the maximum of 90 litres, is forbidden.

6.5.2) The right is reserved, by the Sporting Authority of the relevant Championship, to adjust the size of the fuel tank to maximise equality of performance.

ARTICLE 7 : LUBRICATION SYSTEM

Provided the regulations in this Article are complied with, the lubrication system is free.

7.1 Oil tanks

No vessel or line containing oil is permitted in the cockpit, more than 650 mm (external measurement) from the longitudinal centre line of the car, aft of the gearbox or in a vulnerable area.

If the oil tank is outside the wheelbase, it must be surrounded by a 10 mm thick crushable structure.

7.2 Catch tank

When a car's lubrication system includes an open type sump breather, it must vent into a catch tank of at least 3 litres capacity.

ARTICLE 8 : ELECTRICAL EQUIPMENT

Provided the regulations in this Article are complied with, the electrical system is free.

8.1 Battery

Batteries must be securely fixed and completely surrounded by a box made of insulating material. If located in the cockpit they must be in the place of the co-driver, and the protection box must include an air vent which exits outside the cockpit.

If the battery situated in the cockpit is a dry battery, it must be protected electrically by a cover which covers it completely.

8.2 Starting

A starter must be fitted and be in working order at all times during an event.

The driver must also be able to operate the starter when seated normally.

8.3 Lighting equipment

8.3.1) All lighting equipment must be in working order at all times during the Event.

8.3.2) Headlights :

The car shall be fitted with at least 2 headlights, the centres of which must be symmetrical around the longitudinal centre line of the car and separated by at least the width of the front track.

For safety reasons, it is obligatory for headlights to produce a white beam.

8.3.3) Rear lights and Stop lights :

The car shall be fitted with two rear lights and two stop lights located symmetrically around the longitudinal centre line of the car and separated by at least the width of the rear track.

8.3.4) Direction indicators :

The car shall be fitted with direction indicators fitted on either side at the front and at the rear.

8.3.5) Light for rain

All cars must have a red light of at least 21 watts, in working order throughout the event, which:

- is a model approved by the FIA.
- faces rearwards at 90° to the car centre line.
- is clearly visible from the rear.
- is mounted not more than 10cm from the car centre line.
- is at least 35 cm above the reference plane.
- is no less than 45 cm behind the rear axle centre line, measured to the face of the lens and parallel to the reference plane.
- can be switched on by the driver when seated normally in the car.

The three measurements being taken to the centre of area of the lens.

ARTICLE 9 : TRANSMISSION

Provided the regulations in this Article are complied with, the transmission system is free.

9.1 Transmission to the wheels

9.1.1) Four wheel-drive is forbidden.

9.1.2) The location, position and orientation of the gearbox must remain identical to those specified on the technical form of the car, as well as its make and type.

The gearbox must comprise a maximum of 6 ratios and a reverse gear.

Sequential gearbox systems are allowed.

9.1.3) Viscous differentials are not considered to have hydraulic slip control, provided outside control is not possible when the car is in motion.

9.1.4) For safety reasons, the transmission must be designed in such a way that should the car be stopped and the engine stalled, it is possible to push or tow it.

9.2 Reverse gear

All cars must have a reverse gear which, at any time during the event, can be selected while the engine is running and used by the driver when seated normally.

9.3 Clutch

A conventional design, physically operated either mechanically or hydraulically by the driver, is mandatory.

ARTICLE 10 : SUSPENSION AND STEERING

10.1 Sprung suspension

Cars must be fitted with sprung suspension.

The anchorage points of the suspensions must not consist solely of bolts located through flexible bushes or mountings.

There must be movement of the wheels to give suspension travel in excess of any flexibility in the attachments.

10.2 Suspension type and mounting

10.2.1) The position of the suspension anchorage points on the chassis must be identical to those specified on the technical form of the car.

10.2.2) The material, number and dimensions of the springs are free.

The modification of spring and shock absorber adjustments from the cockpit is prohibited.

10.2.3) Shock absorbers are free provided their number remains identical to the one specified on the technical form of the car.

10.3 Chromium plating

Chromium plating of steel suspension members is forbidden.

10.4 Suspension members

All suspension members must be made from a homogeneous metallic material.

Except for front-engined cars, a bar must mandatorily be fitted at the base of the front suspension wishbones if these are dangerous for the driver's legs.

10.5 Steering

The steering is free but must consist of a mechanical link between the driver and the wheels and must comply with the one specified on the technical form of the car.

The shape of the steering wheel is free but its rim must be continuously closed.

A quick-release steering wheel mechanism is mandatory.

10.6 Power steering

Power steering is permitted.

10.7 Four-wheel steering

The use of four-wheel steering is forbidden.

ARTICLE 11 : BRAKES

11.1 Separate circuits

With the exception of the restrictions set out below, the complete braking system is free provided it incorporates at least two separate circuits operated by the same pedal.

This system must be designed so that if leakage or failure occurs in one circuit, the pedal shall still operate the brakes on at least two wheels.

11.2 Brake discs

~~Carbon brake discs are prohibited.~~

A maximum of one brake disc per wheel is permitted, with a maximum of two pads.

11.3 Anti-lock braking and power braking

Any anti-lock braking function and any power braking function are prohibited.

11.4 Brake callipers

All the brake callipers must be made from aluminium alloy with a modulus of elasticity no greater than 80Gpa.

A single calliper, with a maximum of 8 pistons, is permitted on each wheel.

The section of each calliper piston must be circular.

ARTICLE 12 : WHEELS AND TYRES

12.1 Dimensions

12.1.1) Complete wheels :

Maximum width : 16".

Maximum diameter : 28.5".

Measurements will be taken horizontally at the height of the axle centre line.

12.1.2) Wheels :

The maximum authorised diameter of the rims is 18".

All the rims must be of the same diameter.

12.2 Wheel visibility

The complete wheel above the hub centre line must not be visible in plan view, with the wheels aligned for the car to proceed straight ahead.

12.3 Wheel material

Wheel material is free, provided that it is homogeneous and metallic.

The front wheel must weigh a minimum of 8 kg.

The rear wheel must weigh a minimum of 9 kg.

12.4 Number of wheels

The maximum number of wheels is four.

12.5 Wheel attachment

Wheel attachment is free but if a single wheel nut is used, a safety spring must be in place on the nut or on the stub axle whenever the car is running, and must be replaced after each wheel change.

These springs must be painted dayglo red or orange.

Alternatively, another method of retaining the wheels may be used, provided it has been approved by the FIA.

12.6 Pneumatic jacks

Pneumatic jacks may be fitted to the car, but compressed air bottles are not to be carried on board.

12.7 Pressure control valves

Pressure control valves on the wheels are forbidden.

ARTICLE 13 : COCKPIT

13.1 Cockpit

The cockpit shall be designed to ensure the best protection of the driver in the event of a crash or upset.

13.2 Cockpit opening

The cockpit opening (including the windscreen) must be at least 900 mm in width and 700 mm in length.

These measurements shall be maintained for at least 80% to provide for radii in the corners.

Nothing will be permitted on top of the cockpit opening.

13.3 Volumes for occupants' legs

Two volumes of equal dimensions, defined by flat, rectangular surfaces, symmetrical around the longitudinal centre line of the car, must be provided for the legs of both occupants.

The only components allowed to intrude into these volumes, any other being excluded, will be the steering column and its joints.

Measurements of the volumes (to be enforced on all dimensions):

a) Length : from the pedals to the vertical projection of the centre of the steering wheel.

b) Width : 330 mm minimum.

c) Height : 300 mm minimum.

13.4 Cockpit exit time

13.4.1) The cockpit must be designed so as to allow the driver to get out from his normal driving position in 7 seconds.

13.4.2) For the purposes of the above test, the driver must be wearing all normal driving equipment, the seat belts must be fastened and the steering wheel must be in place in the most inconvenient position.

13.5 Protection of the driver

The areas adjacent to the driver must include materials which provide an anti-penetrant barrier.

13.6 Lateral protections

The chassis-body structure must provide a lateral protection at least 500 mm high from the floor up to the cockpit opening and along the total length of the opening.

The vertical planes of the lateral protections must be separated by a minimum of 900 mm.

13.7 Cockpit isolation

The cockpit shall be separated from the fuel tank and from the engine compartment by means of metallic firewalls with no holes.

13.8 Equipment permitted in the cockpit

13.8.1) The following equipment alone is permitted in the cockpit but outside the two volumes prescribed in Article 13.4 :

- Safety equipment and structures
- Tool kit
- Seat(s)
- Controls necessary for driving
- Electronic equipment
- Driver cooling system
- Ballast
- Pneumatic jacks (no compressed air bottles to be carried on board)
- Battery(ies)
- Driver ventilation equipment

13.8.2) None of the above items may hinder cockpit exit.

13.8.3) The above components must be covered where necessary by a rigid protective material to minimise injury and must be attached such that they are able to withstand 25 g deceleration.

ARTICLE 14 : SAFETY EQUIPMENT

14.1 Fire extinguishers

The use of the following products is prohibited: BCF, NAF

All cars must be equipped with an extinguishing system homologated by the FIA in accordance with article 253-7.2, with the exception of the means of triggering.

A means of triggering from the outside must be combined with the circuit breaker switch and be operated by a single lever. It must be marked with a letter "E" in red inside a white circle of at least 100 mm diameter with a red edge.

14.2 Safety belts

The wearing of two shoulder straps, one abdominal strap and two straps between the legs is compulsory.

These straps must comply with FIA standard N°8853/98.

It is prohibited for the seat belts to be anchored to the seats or their supports.

14.3 Rear view mirrors

Position free.

The car must be fitted with two rear view mirrors, one fitted on each side of the car, in order to give an efficient view to the rear. Each mirror must have a minimum area of 100 cm².

The scrutineers must be assured through a practical demonstration that the driver, seated normally, can clearly see the vehicles following him.

To this end, the driver will be asked to identify letters or figures, 15 cm high and 10 cm wide, displayed at random on boards placed behind the car according to the following instructions :

- Height : Between 40 cm and 100 cm from the ground.
- Width : 2 m one side or the other of the centre line of the car.
- Position : 10 metres behind the centre line of the rear axle of the car.

14.4 Seat and headrest

14.4.1) It must be possible to fit two seats of equal shape and size (excluding shoulder supports) symmetrically around the longitudinal centre line of the car.

14.4.2) All cars must be equipped with a headrest which cannot deflect more than 50 mm when a rearward force of 85 daN is applied.

The headrest surface must not be less than 400 cm² and must be continuous and without protruding parts.

It must be positioned so that it is the first point of contact for the driver's helmet in the event of an impact projecting his head backwards when he is seated normally.

14.5 Master switch

14.5.1) The driver, when seated normally with the safety belt fastened and the steering wheel in place, must be able to cut off all the electrical circuits by means of a sparkproof circuit breaker switch.

This switch must be clearly marked by a symbol showing a red spark in a white-edged blue triangle and be accessible by the driver with his safety belt fastened.

14.5.2) There must also be an exterior switch, with a handle which is capable of being operated from a distance by a hook.

This switch must be located at the lower part of the main rollbar on the driver's side.

14.6 Towing eye

14.6.1) Two towing eyes with an inner diameter of between 80 mm and 100 mm, and a thickness of at least 5 mm, must be securely fitted to the front and rear parts of the car's chassis.

14.6.2) They must be positioned in such a way that they can be used should the car be stopped in a gravel bed.

14.6.3) The towing eyes must be clearly visible and painted in yellow, red or orange.

14.6.4) If a lifting / towing area is located on the main rollbar, it must be clearly identified with a dayglo yellow surround.

ARTICLE 15 : SAFETY STRUCTURES

15.1 Magnesium

The use of magnesium sheet less than 3 mm thick is forbidden.

15.2 Survival cell

The chassis structure must include a survival cell extending from behind the fuel tank to a plane at least 150 mm in front of the soles of the driver's feet, with his feet resting on the pedals and the pedals in the inoperative position.

This survival cell must be from a type approved by the FIA.

A test certificate is drawn up by the FIA, according to the approval procedure featuring in appendix 2.

A copy of this certificate must be delivered by the manufacturer to the competitor.

15.3 Frontal absorbing structure

An impact absorbing structure must be fitted in front of the survival cell.

This structure needs not be an integral part of the survival cell but must be solidly attached to it.

This frontal absorbing structure must be from a type approved by the FIA.

A test certificate is drawn up by the FIA, according to the approval procedure featuring in appendix 2.

A copy of this certificate must be delivered by the manufacturer to the competitor.

15.4 Rollover structures

Front and rear rollover structures are mandatory and must be solidly attached to the survival cell or be part of it.

The front and rear structures must be separated by at least 760 mm longitudinally.

The driver's helmet must not extend higher than the line directly above the driver's head connecting the forward and rear rollover structures.

With the driver seated at the wheel, the rear rollover structure shall be at least 100 mm above the top of the driver's helmet.

In all cases, the tubes close to the driver must be padded with non-flammable foam approved by the FIA.

15.4.1) Material :

a) Rollover structures must be made of seamless mild steel or a higher-grade steel alloy.

The tubes must have a minimum outside diameter of 45 mm or 50 mm (1.75") and a minimum wall thickness of 2.3 mm or 2.5 mm (0.09").

b) The use of components of a different type and/or made from different materials from those specified in article 15.4.1a) is permitted, provided that their mechanical characteristics are equivalent or greater.

15.4.2) Front rollover structure :

It must meet the following requirements :

- be symmetrical in relation to the longitudinal centre line of the car.

- its upper part shall be 660 mm minimum above the flat bottom.

- no part of the steering wheel, whatever its position, may be higher than the rollover structure.

15.4.3) Rear rollover structure :

It must meet the following requirements :

- be symmetrical in relation to the longitudinal centre line of the car.

- have a minimum overall width of 900 mm at the level of the mountings on the survival cell.

- have a diagonal reinforcement bar starting from the top of the hoop on the driver's side and connected as a minimum to the middle point of the survival cell.

- have two rearward facing braces connected to the top of the hoop.

- the upper section of the rollbar must have a horizontal part of 500 mm minimum length measured transversally and shall be at least 1020 mm above the flat bottom.

Streamlining or fairing of the rear rollover structure is permitted no more than 200 mm measured longitudinally, and provided that any section of this streamlining or fairing is symmetrical relative to a longitudinal axis passing through the rollbar tubing centre at that section.

The fairing must not cover the rollbar mounting area over the survival cell, or have any aerodynamic influence.

15.4.4) All facilities must be made available for possible inspections by the scrutineers.

15.4.5)

- For cars built as from 01/01/2002 :

The rollover structures must comply with articles 15.4.1 to 15.4.4 and must be approved by the FIA.

A test certificate is drawn up by the FIA, according to the approval procedure featuring in appendix 2.

A copy of this certificate must be delivered by the manufacturer to the competitor.

- For cars built before 01/01/2002 :

The rollover structures must comply with articles 15.4.1 to 15.4.4 and must be approved by the FIA, unless the dimensions and/or material used are those specified in article 15.4.1a).

If articles 15.4.2 and 15.4.3 are not complied with, except with regard to the height, cars will nevertheless be accepted.

A test certificate is drawn up by the FIA, according to the approval procedure featuring in appendix 2.

Only the rear rollover structure must be the subject of a test certificate if the car was built before 01/01/2000.

15.5 Modification of a safety structure

Any modification made to a safety structure shall be submitted by the manufacturer or competitor to the prior examination of the FIA. The FIA will decide if a new approval procedure and therefore a new test certificate are necessary.

15.6 Firewall

Cars must be equipped with a firewall which is liquid-proof, flameproof and gas-proof between the driver and engine to prevent the passage of flames from the engine compartment to the cockpit.

Any holes in the firewall must be of the minimum size for the passage of controls and wires and must be completely sealed.

15.7 Composite chassis

For any vehicle equipped with a composite chassis, any repairs to the survival cell or to the frontal protection must be carried out according to the manufacturer's specifications, in a repair centre approved by the manufacturer.

Any important damage must be entered on the technical passport.

ARTICLE 16 : FUEL

16.1 Fuel specification

The fuel must be commercial petrol which comes from a service station pump, without any additive other than that of a lubricant on current sale. The fuel must comply with the following specifications:

- 102.0 RON and 90.0 MON maximum, 95.0 RON and 85.0 MON minimum for unleaded fuel.

- 100.0 RON and 92.0 MON maximum, 97.0 RON and 86.0 MON minimum for leaded fuel.

The measurements will be made according to the standards ASTM D 2699-86 and D 2700-86.

- Specific gravity between 720 and 785 kg/m³ at 15°C (measured according to ASTM D 4052).

- A maximum of 2.8% oxygen (or 3.7% if the lead content is less than 0.013 g/l) and 0.5% nitrogen by weight, the remainder of the fuel consisting exclusively of hydrocarbons and not containing any power-boosting additives.

The measuring of the nitrogen content will be carried out according to the standard ASTM D 3228 and that of the oxygen content by elemental analysis with a tolerance of 0.2%.

- Maximum content of peroxides and nitrooxide compounds: 100 ppm (ASTM D 3703 or in the case of impossibility UOP 33-82).
- Maximum lead content: 0.40 g/l or the standard of the country of the event if it is lower (ASTM D 3341 or D 3237)
- Maximum benzene content: 5% in volume (ASTM D 3606).
- Maximum Reid vapour pressure: 900 hPa (ASTM D 323).
- Distillation at 70°C: 10% - 47% (ASTM D 86).
- Distillation at 100°C: 30% - 70% (ASTM D 86).
- Distillation at 180°C: 85% minimum (ASTM D 86).
- Maximum final boiling point: 225°C (ASTM D 86).
- Maximum residue: 2% volume (ASTM D 86).

The fuel will be accepted or rejected according to the standard ASTM D 3244 with a confidence limit of 95 %.

If the fuel available locally for the event is not of a sufficient quality for use by competitors, the ASN of the organising country must ask the FIA for a waiver in order to enable the use of fuel not corresponding to the characteristics defined above.

16.2 Air

Only air may be mixed with the fuel as an oxidant.

ARTICLE 17 : SPORT RACING CARS LIGHT

Articles 1 to 16 apply, with the following modifications:

3.2 Overhangs and wheelbase

- Minimum wheelbase: 2525 mm
- Front plus rear overhangs must not exceed 80 % of the wheelbase.
- The difference between the front and rear overhangs must not exceed 15 % of the wheelbase.

3.6 Aerodynamic devices

- 3.6.4) Rear diffuser :
Tunnels, ducts, skirts, diffusers, extractors or other devices for the purpose of inducing downforce, whether using the exterior shape of the body or not, are prohibited behind the front axle centre line.
- Any rear diffuser is forbidden.

4.1 Minimum weight

- 4.1.1) The weight of the car must not be less than 720 kg.

5.1 Engine: General

Normally aspirated engine derived from a volume production engine with a maximum of 6 cylinders.

- 5.2.3) Titanium is forbidden except for series production parts commonly on sale.
- 5.3.1) Cylinder capacity :
The cylinder capacity must be between 2700 and 3000 cm³.
- 5.3.2) The engine air intake system must be fitted with one air restrictor with a maximum diameter of 38 mm or two air restrictors with a maximum diameter of 27.2 mm each.

6.5 Fuel capacity

- 6.5.1) The maximum amount of fuel which may be carried on board is 60 litres.

11.2 Brake discs

They must be made from ferrous material.
They must have a maximum diameter of 330 mm and a maximum thickness of 32 mm.
The drilling of the friction surface is forbidden.

11.4 Brake callipers

All the brake callipers must be made from aluminium alloy with a modulus of elasticity no greater than 80 Gpa.
A single calliper, with a maximum of 4 pistons, is permitted on each wheel.

12.1 Dimensions of wheels and tyres

- 12.1.1) Complete wheels :
Maximum width: 12.5".
- 12.1.2) Wheels :
The diameter of the rims must be 18".

The width of the front wheels must be between 10" and 10.5" and the width of the rear wheels must be between 11" and 11.5".

12.3 Wheel material

- The front wheel must weigh a minimum of 7.5 kg.
- The rear wheel must weigh a minimum of 8.5 kg.

15.2 Survival cell

The survival cell must be made neither from carbon nor from Kevlar nor from any material with a modulus of elasticity greater than that of fibreglass.

ARTICLE 18 : FINAL TEXT

The final text of these regulations is the English version which shall be used should any dispute arise over their interpretation.

ARTICLE 19 : MODIFICATIONS FOR 01/01/2002

"Sports Racing Cars" is replaced with SR1.
"Sports Racing Cars Light" is replaced with SR2.



1.8 Weight

Is the weight of the car without the driver at any moment during the event and without fuel.



2.4 Regulation and eligibility amendments

.....
Changes covered by Articles 4.1.2, 5.3.4, 5.4.5, **5.4.8** and 6.5.2 will be made in accordance with the period of notice specified in the relevant Sporting Regulations, save in circumstances deemed to be exceptional by the governing body of the relevant Championship.



3.6.3) Rear wing :

.....
The rear wing is made of the following parts :
Main-wing, Guard **and** plates, vertical supports **and must comply with the following points :**
- It must be no wider than the overall width of the car measured at the rear axle centre line.
- It must be mounted such that no part is higher than 965 mm above the Reference Surface (Flat bottom).

- Wing :
- it is made of a maximum of 2 elements (main wing and flap),
- ~~The main-wing it~~ must be contained within a parallelogram of 150 x 400 mm horizontally 150 mm vertically by 400 mm horizontally.
- End plates and vertical supports :
- Vertical supports and guard plates they must have a maximum length of 520 400 mm horizontally.
- The their surfaces of the guard-plates must not be curved and must be parallel to the longitudinal axis of the car.
- their leading edges must be rounded with a constant radius and the trailing edges may be bevelled along a 20 mm maximum length.
- the end plates must have a maximum height of 150 mm vertically.
~~- The gap between the guard-plates and the bodywork must never be less than 100 mm.~~
- the distance between the supports must not be greater than 1650 mm.

Only for cars designed as from after 1 January 2000 :
The rear wing must be rigidly attached to the main structure of the car, and not just to the bodywork.



4.4 Liquids

The weight may be checked at any time during the event with the quantity of liquids remaining in the tanks except after the race where the car will may be emptied of all the fuel before weighing.

❖❖❖

5.4.8) Maximum (absolute) supercharging pressure :
See table, Appendix 1.

The right is reserved, by the Sporting Authority of the relevant Championship, to adjust the supercharging pressure to maximise equality of performance.

❖❖❖

11.4 Brake callipers

All the brake callipers must be made from aluminium alloy with a modulus of elasticity no greater than 80Gpa.

A single calliper, with a maximum of 8 6 pistons, is permitted on each wheel.

The section of each calliper piston must be circular.

❖❖❖

13.2 Cockpit opening

.....
Nothing will be permitted on top of the cockpit opening.

❖❖❖

13.5 Protection of the driver

.....
For cars built as from 01/01/2002 and for all cars as from 01/01/2004 :

The cockpit must be fitted with a protection structure surrounding the driver, attached to or integrated into the survival cell and positioned between the front and rear rollover structures.

This structure must have the minimum dimensions specified on drawing 258A-1.

The lateral surfaces close to the driver must be padded with non-flammable foam approved by the FIA.

In the helmet area, the foam thickness must not be less than 75 mm over a minimum length of 300 mm (see drawing 258A-1).

❖❖❖

15.2 Survival cell

.....
For cars built as from 01/01/2002 :

Secondary rollover structure :

The part of the survival cell situated rearward of the driver must form a secondary rollover structure, the purpose of which is to protect the occupants in the case of a failure of the main rear rollover structure described in article 15.4.3.

Viewed from the front, this structure must always extend beyond the outline of the driver's helmet and must be symmetrical about the vertical plane passing through the longitudinal axis of the car and about the driver.

Its external sides must form an angle of 40° minimum to one another (see drawing 258A-2).

❖❖❖

15.4 Rollover structures

15.4.1) General

.....
For cars built as from 01/01/2002 :

Viewed from the side, the driver's helmet must be at a minimum distance of 80 mm from the straight line passing

through the tops of the front and rear rollover structures (see drawing 258A-3).

All facilities must be made available for possible inspections by the scrutineers.

15.4.4 2) Material :

.....

15.4.4 3) Front rollover structure :

It must meet the following requirements :

–be symmetrical in relation to the longitudinal centre-line of the car.

.....

15.4.4 4) Rear rollover structure :

It must meet the following requirements :

–be symmetrical in relation to the longitudinal centre-line of the car.

- have a minimum overall width of 900 mm at the level of the mountings on the survival cell.

–have a diagonal reinforcement bar starting from the top of the hoop on the driver's side and connected as a minimum to the middle point of the survival cell.

–have two rearward facing braces connected to the top of the hoop.

–the upper section of the rollbar must have a horizontal part of 500 mm minimum length measured transversally and shall be at least 1020 mm above the flat bottom.

- be at least 1020 mm above the flat bottom.

- In the case of a single structure for the two occupants :

The upper section of the structure must have a horizontal part of 500 mm minimum length measured transversally.

- In the case of a tubular structure :

It must have a diagonal reinforcement bar, starting from the top of the structure on the driver's side and connected as a minimum to the middle point of the survival cell (only for cars built before 01/01/2002), and two rearward facing braces connected to the top of the structure.

Supplementary requirements for cars built as from 01/01/2002 :

The structure must :

- have a minimum overall length of 200 mm measured at the level of the mountings on the survival cell.

- have a minimum height of 165 mm relative to the secondary rollover structure of the survival cell, described in article 15.2 (see drawing 258A-4).

- on a frontal projection, the external sides must form an angle of 30° minimum to one another (see drawing 258A-4).

15.4.4) All facilities must be made available for possible inspections by the scrutineers.

15.4.5) Test certificate

–For cars built as from 01/01/2002 :

The rollover structures must comply with articles 15.4.1 to 15.4.4 and must be approved by the FIA.

A test certificate is drawn up by the FIA, according to the approval procedure featuring in appendix 2.

A copy of this certificate must be delivered by the manufacturer to the competitor.

– For cars built before 01/01/2002 :

The rollover structures must comply with articles 15.4.1 to 15.4.4 and must be approved by the FIA, unless the dimensions and/or material used are those specified in article 15.4.1a.

If the dimensions and/or material used are those specified in article 15.4.1a, the rollover structures do not have to be approved by the FIA.

If articles 15.4.2 and 15.4.3 are not complied with, except with regard to the height, cars will nevertheless be accepted.

A test certificate is drawn up by the FIA, according to the approval procedure featuring in appendix 2.

Only the rear rollover structure must be the subject of a test certificate if the car was built before 01/01/2000.

DRAWINGS VALID AS FROM 01/01/2002

Dessin / Drawing 258A-1

 Mousse
Foam

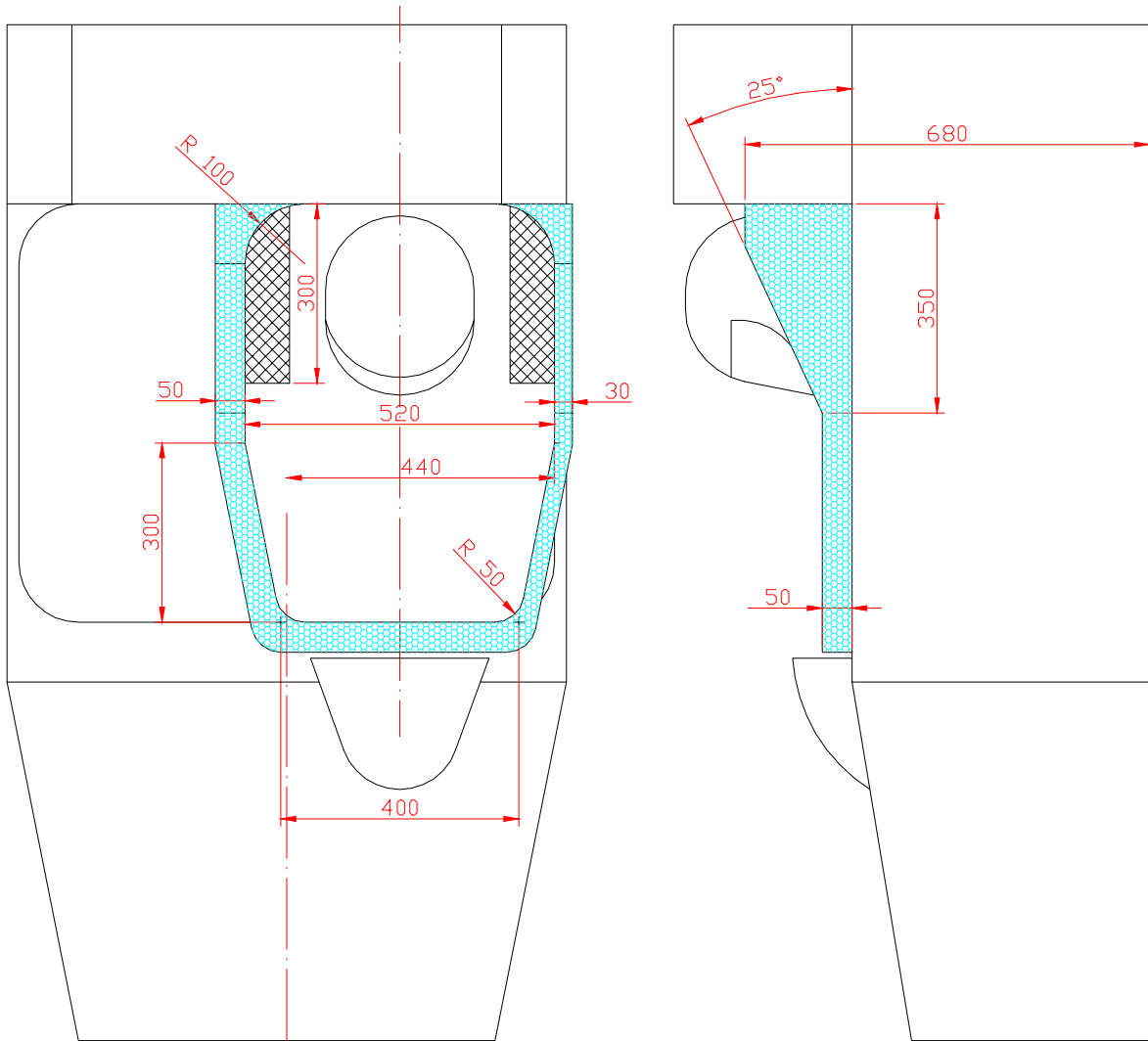
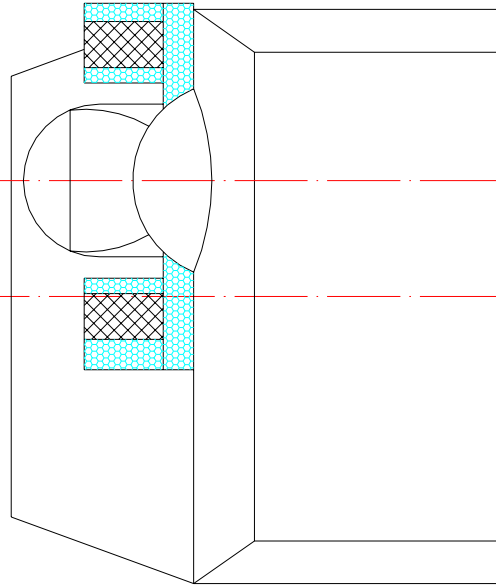

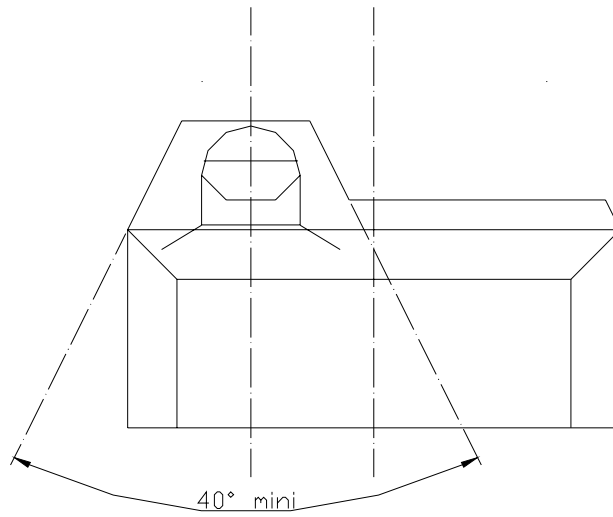

Dessin / Drawing 258A-2

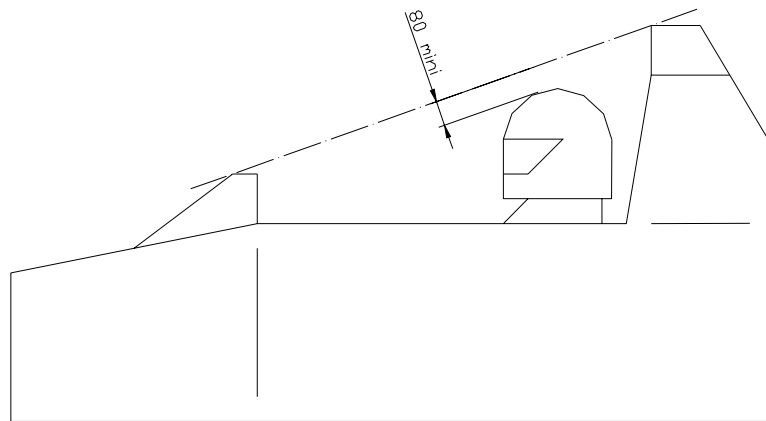

Dessin / Drawing 258A-3

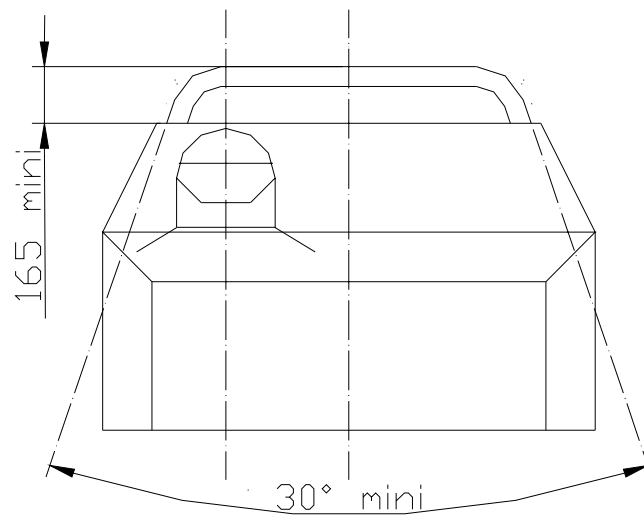

Dessin / Drawing 258A-4

258A (Sports Racing Cars) - Appendix 1

Restrictors for Normally Aspirated Engines (Diameter in mm)

	5 valves / cylinder		More than 2 valves / cylinder		2 valves / cylinder				Rotary engines	
	position of camshaft(s)				Overhead		In block			
number of restrictors	1	2	1	2	1	2	1	2	1	2
up to 3000 cm ³	47.3	33.8	47.8	34.1	49,4	35,3	48.9	35.2	52.5	37.4
over 3000 cm ³ and up to 3500 cm ³	47.3	33.8	47.3	33.8	48,9	34,9	48.9	35.2	51.9	37.1
over 3500 cm ³ and up to 4000 cm ³	47.3	33.8	46.8	33.4	48,4	34,6	48.9	35.2	51.4	36.6
over 4000 cm ³ and up to 4500 cm ³			46.3	33.1	47,8	34,1	48.9	35.2	50.8	36.3
over 4500 cm ³ and up to 5100 cm ³			45.9	32.8	47,4	33,9	48.9	35.2	50.4	36
over 5100 cm ³ and up to 5500 cm ³			44.9	32.1	46,4	33,1	47.7	34.1	49.3	35.2
over 5500 cm ³ and up to 6000 cm ³			44.4	31.2	45,9	32,8	46.4	33.2	48.7	34.2

Restrictors for Supercharged Engines (Diameter in mm)

	1 restrictor	2 restrictors
More than 2 valves / cylinder	45.4	32.4
2 valves / cylinder	48,3	34.5

Supercharging pressure for Supercharged Engines (mbar)

Cylinder capacity (cm ³)	2000	2200	2400	2600	2800	3000	3200	3400	3600	3800	4000
Max pressure (mbar) More than 2 valves / cylinder	3000	2730	2500	2310	2150	2000	1880	1770	1670	1580	1500
Max pressure (mbar) 2valves / cylinder	3410	3100	2840	2630	2440	2270	2130	2010	1900	1790	1700

258A (Sports Racing Cars) - Appendix 2

APPROVAL OF SAFETY STRUCTURES FOR SPORTS RACING CARS

ARTICLE 1 : APPROVAL PROCEDURE FOR SAFETY STRUCTURES

1.1 Safety structures

The following safety structures may be the subject of FIA approval :

- Survival cell
- Frontal absorbing structure
- Front and rear rollover structures

1.2 Request for approval

In order to obtain the approval of one of the above-mentioned safety structures, the FIA must first of all receive a written request from the manufacturer or competitor at the following address:

**FIA Technical Department
Chemin de Blandonnet 2,
CH1215 Geneva 15
Switzerland**

For the tests described in article 2, no approval will be possible without an FIA technical delegate in attendance and without the use of measuring equipment verified by the FIA.

1.3 Approval procedure

- On receipt of the written request, the FIA will send a technical dossier to the manufacturer or competitor, to be filled in and sent back to the FIA.
- On receipt of this dossier, the FIA will decide if the necessary tests may be carried out.
- The manufacturer or the competitor will then propose to the FIA a date and venue for each test, and the FIA will appoint a technical delegate to supervise each of the scheduled tests.
- For each trip made by an FIA technical delegate, the manufacturer or competitor who made the request for approval will be charged 2500 CHF.
- On receipt of the report from the technical delegate, the FIA will draw up a certificate for each safety structure that has successfully undergone the tests necessary for its approval, and will send it to the manufacturer or competitor.
- The manufacturer or competitor will provide all information and documents that the FIA deems necessary for drawing up the certificates.

ARTICLE 2 : APPROVAL TESTS FOR SAFETY STRUCTURES

2.1 Survival cell

The survival cell must be subjected to three separate static load tests.

2.1.1) Side load tests on the survival cell :

A constant transversal and horizontal load of 2000 daN shall be applied through a ball-jointed junction at the centre of area of a pad :

- On a vertical plane passing halfway between the front wheel axis and the centre of the dashboard.
- In the cockpit area on a vertical plane passing through the centre of the seat belt lap strap fixing.
- In the fuel tank area on a vertical plane passing through the centre of area of the fuel tank in side elevation.

It must be applied in less than 3 minutes and maintained for a minimum of 30 seconds.

The survival cell must be fixed onto the test device in such a way that its transversal displacement is left free and its rigidity not modified.

This transversal displacement must be blocked through a pad identical to the one used to apply the load and positioned symmetrically relative to it (see diagram 1).

These pads must :

- be 100 mm long and 300 mm high, with a maximum radius on all edges of 3 mm

- conform to the shape of the survival cell at that section

- be placed against the outermost sides of the survival cell with the lower edge of the pad at the lowest part of the survival cell at that section.

It is permissible to place rubber 3 mm thick between the pads and the survival cell.

Under these load conditions, there shall be no structural failure of the inner or outer surfaces of the survival cell.

The deformation shall be measured at the top of the pads across the inner surfaces of the survival cell, and any permanent deformation must be less than 1 mm after the load has been released for 1 minute.

2.2 Frontal absorbing structure

The frontal absorbing structure must be subjected successively to a static side load test and a crash test.

2.2.1) Side load test on the frontal absorbing structure :

To test the attachments of the frontal absorbing structure to the survival cell, a static side load test shall be performed on a vertical and transversal plane passing 500 mm forward of the front wheel axle.

For this test, it is possible to use :

- The frontal absorbing structure and the front part of the survival cell extending to a minimum of 200 mm to the rear of the soles of the driver's feet in the inoperative position with the pedal box in its furthest forward mounting position. This part must be totally representative of the survival cell
- or
- The frontal absorbing structure and the complete survival cell.

A constant transversal and horizontal load of 2000 daN must be applied to one side of the frontal absorbing structure using a pad identical to the one used in the side load tests on the survival cell.

The centre of area of the pad must pass through the vertical and transversal plane mentioned above and the mid point of the height of the structure at that section.

During that test, the front part of the survival cell or the complete survival cell must be solidly secured to a flat plate but not in such a way as to increase the strength of the attachments being tested, and must be blocked laterally through a pad of identical dimensions to the one used to apply the load, positioned before the junction with the frontal absorbing structure (see diagrams 2 and 3).

After 30 seconds of application, there must be no failure of the structure or of any attachment between the structure and the survival cell.

2.2.2) Crash test :

There are two possibilities for carrying out the crash test :

a) Crash testing of the frontal absorbing structure :

The frontal absorbing structure and the front part of the survival cell extending to a minimum of 200 mm to the rear of the soles of the driver's feet in the inoperative position with the pedal box in its furthest forward mounting position, must be subjected to an impact test against a solid, vertical barrier placed at right angles to the longitudinal axis of the car.

The frontal absorbing structure and the front part of the survival cell must previously have been subjected to the side load test described in article 2.2.1.

The front part of the survival cell to be tested must be solidly attached to the trolley in such a way as not to increase its impact resistance and must be totally representative of the survival cell.

For the purpose of the test, the total weight of the trolley and test structures shall be 900 kg (minimum weight defined in article 258A-4.1.1) + 150 kg and the velocity of impact 12 m/s.

For Sports Racing Cars Light, the total weight of the trolley and test structures shall be 720 kg (minimum weight defined in article 258A-17) + 180 kg and the velocity of impact 12 m/s.

During the test, the maximum average deceleration of the trolley must not exceed 25 g and the final deformation must be contained within the zone situated more than 100 mm ahead of the driver's feet.

b) Crash testing of the complete chassis :

The frontal absorbing structure and the complete survival cell must be subjected to the same crash test as described in article 2.2.2 a.

The frontal absorbing structure and the front part of the survival cell must previously have been subjected to the side load test described in article 2.2.1.

The entire cell must be solidly fixed to the trolley through its engine mounting points but not in such a way as to increase its impact resistance.

The fuel tank must be full of water.

A dummy weighing at least 75 kg must be installed in the survival cell with the safety belts defined in Article 14.2 fastened. The person carrying out the test must check that, with the safety belts unfastened, the dummy must be able to move forwards freely in the cockpit.

The extinguishers, as described in article 258A-14.1, must also be installed.

For the purpose of the test, the total weight of the trolley and test structures shall be 900 kg (minimum weight defined in article 258A-4.1.1) + 150 kg and the velocity of impact 12 m/s.

For Sports Racing Cars Light, the total weight of the trolley and test structures shall be 720 kg (minimum weight defined in article 258A-17) + 180 kg and the velocity of impact 12 m/s.

During the test, the maximum average deceleration of the trolley must not exceed 25 g and the final deformation must be contained within the zone situated more than 100 mm ahead of the driver's feet.

In addition, there must be no damage to the mountings of the safety belts or fire extinguishers.

Furthermore, the peak deceleration in the chest of the dummy must not exceed 60 g for a cumulative time of more than 3ms, this being the resultant of the data from the three axes.

2.3 Rollover structures

Each rollover structure must be subjected to a specific static load test.

The loads to be applied on top of the structure are as follows :

For the front structure :

(only for cars built as from 01/01/2000)

- 5.0 w daN vertically.

For the rear structure :

(to be applied simultaneously)

- 1.5 w daN transversally

- 5.5 w daN longitudinally

- 7.5 w daN vertically.

with w equal to 900 kg (minimum weight defined in article 258A-4.1.1) + 150 kg.

For Sports Racing Cars Light, w equal to 720 kg (minimum weight defined in article 258A-17) + 180 kg.

The resultant of these loads shall be applied through a rigid flat pad with a diameter of 200 mm, positioned perpendicularly to the axis of this resultant.

If the front rollover structure is not directly accessible or is part of the survival cell, the load may be applied straight onto the survival cell, through a plate fitting the cell's local shape and it will be permissible to place rubber 3 mm thick between the pad and the survival cell.

The rollover structure must be attached to the survival cell.

The survival cell must be supported on its underside on a flat plate, fixed to it through its engine mounting points and wedged laterally by pads 100 mm wide by 300 mm long.

The deformation must be less than 50 mm, measured along the axis of load application, and any structural failure must be limited to 100 mm below the top of the rollover structure, measured vertically.

ARTICLE 3 : MODIFICATIONS FOR 01/01/2002

"Sports Racing Cars" is replaced with SR1.

"Sports Racing Cars Light" is replaced with SR2.



1.3 Approval procedure

.....

• For each trip made by an FIA technical delegate, the manufacturer or competitor who made the request for approval will be charged according to a fee decided annually by the FIA (2500 CHF for the current year).



2.1.1) Side load tests on the survival cell :

A constant transversal and horizontal load of 2000 daN shall be applied through a ball-jointed junction at the centre of area of a pad :

• On a vertical plane passing halfway between the front wheel axis and the centre of the dashboard top of the front rollover structure.



2.2.1) Side load test on the frontal absorbing structure :

For Sports Racing Cars and for all cars as from 01/01/2003, this test must mandatorily be carried out on the frontal absorbing structure and the complete survival cell, as defined in article 2.2.1 applicable in 2001.

The test on the frontal absorbing structure and the front part of the survival cell, as defined in article 2.2.1 applicable in 2001, will be authorised only for Sports Racing Cars Light and only until 31/12/2002.



2.2.2) Crash test :

For Sports Racing Cars and for all cars as from 01/01/2003, this test must mandatorily be carried out on the frontal absorbing structure and the complete survival cell, as defined in article 2.2.2 b) applicable in 2001.

The test on the frontal absorbing structure and the front part of the survival cell, as defined in article 2.2.2 a) applicable in 2001, will be authorised only for Sports Racing Cars Light and only until 31/12/2002.

The velocity of impact will be 13 m/s as from 01/01/2003 and 14 m/s as from 01/01/2004.



2.3 Rollover structures

.....

The loads to be applied on top of the structure are as follows :

For the front structure :

(only for cars built as from 01/01/2000)

- 5.0 w daN vertically downward and facing the driver.

For the rear structure :

(to be applied simultaneously behind the driver)

- 1.5 w daN transversally inward

- 5.5 w daN longitudinally rearward

- 7.5 w daN vertically downward.

.....

If the front rollover structure is not directly accessible or is part of the survival cell, the load may be applied straight onto the survival cell, through a plate fitting the cell's local shape, the surface of which must be less than or equal to that of a disc 200 mm in diameter.

It will be permissible to place rubber 3 mm thick between the pad and the survival cell.

For cars built as from 01/01/2002, the load may be applied indiscriminately on one side or the other relative to the longitudinal axis of the car, at the discretion of the FIA technical delegate.